

Model 420L- Specifications



- Accommodates up to 5000 V Cable Voltage
- Extended Temperature Range
- Light Weight
- Small Size
- Encapsulated Shock Resistance
- Metal Encased
- Isolated Two-Wire Transmitters
- Fast, Reliable Response
- Low Cost Industrial Monitor
- Current Overload Protection
- Never Requires Calibration
- Complete Electrical Isolation
- Single Supply Voltage
- Supply Reversal Protection

STANDARD CURRENT RANGES:

A.C. Amps, RMS

0-50, 0-100, 0-150, 0-200, 0-250, 0-300

MAX WEIGHT: 8 OZ.

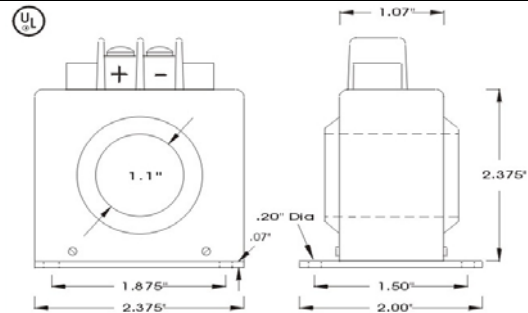

PERFORMANCE SPECIFICATION

With Optimum Load Resistance

Accuracy	0.2% (Standard)
Repeatability	0.1% Full Scale
Response Time	150 Milliseconds Maximum
Temperature Range	-25 deg. C to 85 deg. C
Temperature Coefficient	0.04% F.S./ deg. C
Conductor Cable Voltage	5000 Volts
Supply Voltage	5 to 40 V.D.C.
Signal Out	4 to 20 mA
Frequency	Nominal 50 / 60 Hz

ADDITIONAL SPECIFICATIONS

Conductor Cable Size	Up To 1.10" diameter
Conductor Cable Voltage	Up to 5000 Volts
Isolation	Input/Output/Case
Insulation Resistance (Between Output and Case)	100 Meg. Ohm Min. @ 500 V.D.C.

CHARACTERISTIC CURVE

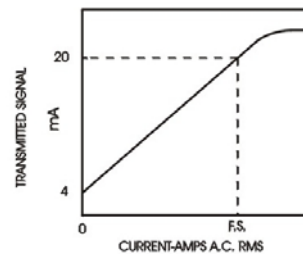

OPTIMUM LOAD RESISTANCE

The optimum load resistance is actually the sum of the line resistance, receiver resistances and added external load resistance. However, in many applications, the line resistance and receiver resistances are negligible in comparison to the added external load resistance. The following equation may apply:

$$R_L = (V_S - 5) \times 40 \quad \text{Where: } R_L = \text{Load Resistance in Ohms.}$$

$$V_S = \text{Supply Voltage in Volts D.C.}$$

